

# TPY 系列离心泵 SERIES STAINLESS STEEL CENTRIFUGAL PUMPS

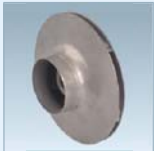

## WORKING CONDITIONS

Max Temperature of Fluid up to +80°C  
Max Pressure 10bar,  
Max Ambient Temperature up to 40°C

## 工作条件:

最高流体温度为80°C  
最大可承受的压力10bar  
最高环境温度40°C

TPY series stainless steel single stage centrifugal pumps, it is designed for industrial use suitable for drinkable water, wine, medicine industry and so on. The hydraulic characteristic is with middle head and large capacity.

TPY 系列为不锈钢单级离心电泵。为工业用而设计，适用输送纯净水、饮用水、酒业、药业等场合。其水力特性为中扬程大流量。



H m PERFORMANCE CHART AT n=2900r/min 折算到2900r/min时性能

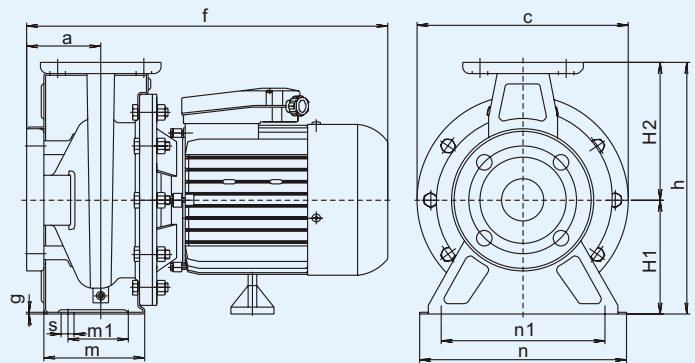
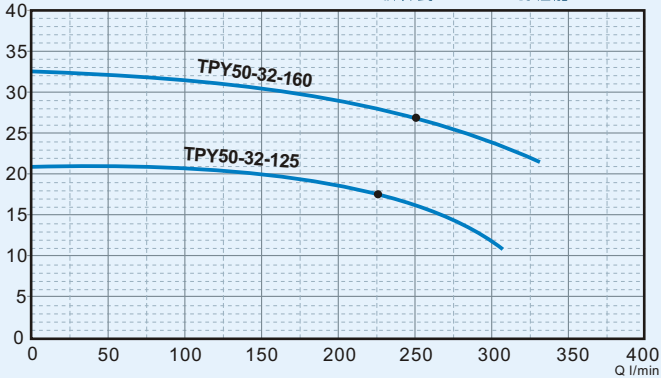

## DIMENSIONS 安装尺寸

TYPE 型号	Dimensions 外形尺寸 mm											Weight 重量 (kg)		Packing Size 包装尺寸 (mm)			Packing QTY. 包装数量
	a	f	h	H1	H2	m	m1	n	n1	g	s	NW	GW	L	W	H	20' Cont 20'柜
TPY50-32-125	86	420	292	132	160	117	70	240	190	2	15	21	23	450	270	315	640
TPY50-32-160	83	420	292	132	160	117	70	240	190	2	15	23	25	450	270	315	640

## TECHNICAL DATA 技术参数

TYPE 型号	Output Power 输出功率		Current 电流 (A)	Capacitor 电容器 (F)	H.max 最高扬程 (m)	Q.max 最大流量 (l/min)	Size 进出口径 (inch)	S.Head 最大吸程 (M)	Total head (m) 总扬程	Capacity 流量 l/min						
	KW	HP								50	100	150	200	250	300	350
TPY50-32-125	1.5	2	8.6	40	21	300	50X25	9		21	20	19.5	19	16	11	
TPY50-32-160	2.2	3	13	50	33	350	50X25	9		33	31	31	30	28	25	

标准的电参数及零件配置：单相220V/50Hz、不锈钢叶轮、不锈钢轴、马达内置热保护器。可根据客户的其它参数及材料的要求，制作其它单、三相电压、60Hz、双电压等规格的产品。  
Standard data and equipment: single phase 220V/50Hz, stainless steel impeller, and stainless shaft, with terminal protector inside.  
Others model and material such as three phase, 110V, 60Hz, dual voltage, will be available upon request.