

FCP 系列游泳池泵

SERIES SWIMMING POOL PUMPS



WORKING CONDITIONS

Max Temperature of Fluid up to +40°C
Max Pressure 10bar,
Max Ambient Temperature up to 40°C

工作条件:

最高流体温度为40°C
最大可承受的压力10bar
最高环境温度40°C

FCP series self-priming pumps are special design for swimming pool, It has a large strainer basket, double insulated from pool water for extra safety. It can be also used for the circulation system of Sauna or other occasion needed water to be filtered clear.

FCP 系列自吸泵专为游泳池的水过滤而设计, 有较大的过滤篮及对水绝缘双保险。它也可以用于桑拿系统中用作循环泵。也可以在需要净水的场合作为过滤泵使用。



H m PERFORMANCE CHART AT n=2900r/min 折算到2900r/min时性能

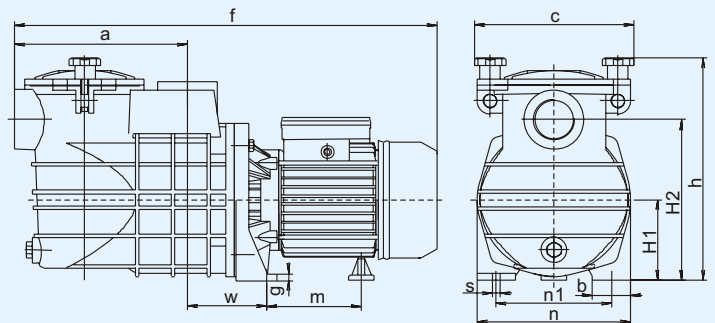
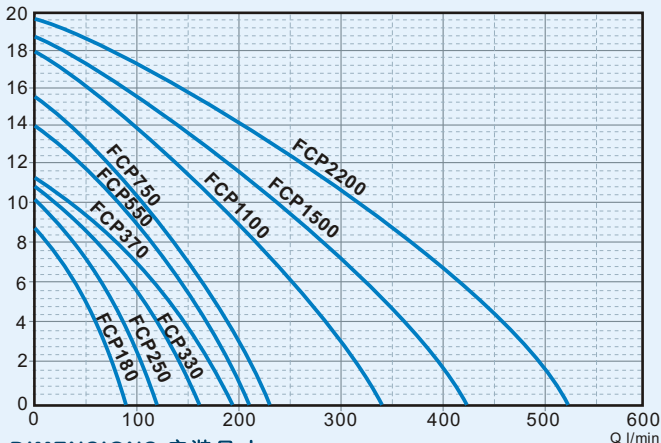

DIMENSIONS 安装尺寸

TYPE 型号	Dimensions 外形尺寸 mm													Weight 重量 (kg)		Packing Size 包装尺寸 (mm)			Packing QTY. 包装数量
	a	f	h	H2	H1	C	m	n	n1	w	b	g	s	NW	GW	L	W	H	20'Cont 20'柜
FCP180	175	438	225	148	88	176	80	158	114	97	40	7	9	6	7	475	190	245	
FCP250	175	438	225	148	88	176	80	158	114	97	40	7	9	6.5	7.5	475	190	245	
FCP330	203	485	263	190	95	188	110	180	136	95	45	8	9	6.5	7.5	530	220	300	
FCP370	203	500	263	190	95	188	110	180	136	95	45	8	9	6.8	7.8	530	220	300	800
FCP550	203	500	263	190	95	188	110	180	136	95	45	8	9	8	9.5	530	220	300	800
FCP750	203	497	263	190	95	188	110	180	136	95	45	8	9	10	11.5	530	220	300	800
FCP1100	220	560	306	222	122	197	160	215	150	95	58	10	16	16	18	610	235	300	750
FCP1500	220	560	306	220	122	197	160	215	150	95	58	10	16	18	20	610	235	300	650
FCP2200	220	600	306	220	122	197	160	215	150	95	58	10	16	20	22	610	235	300	650

TECHNICAL DATA 技术参数

TYPE 型号	Output Power 输出功率		Current 电流 (A)	Capacitor 电容器 (F)	H.max 最高扬程 (m)	Q.max 最大流量 (l/min)	Size 进出口径 (inch)	S.Head 最大吸程 (M)	Capacity 流量 l/min											
	KW	HP							50	100	150	200	250	300	350	400	500			
FCP180	0.18	0.25	1	8	8.5	95	1.5"X1.5"	8	Total head 总扬程 (m)	6										
FCP250	0.25	0.3	1.2	8	10.5	140	1.5"X1.5"	8		7.5	4									
FCP330	0.33	0.45	1.6	12	12	160	1.5"X1.5"	8		8.5	5.5	2								
FCP370	0.37	0.5	2.4	12	11	190	1.5"X1.5"	8		9	7	3.5								
FCP550	0.55	0.75	3.7	16	14	200	1.5"X1.5"	8		11.5	8.2	4.8	2.3							
FCP750	0.75	1	4.4	20	15	220	1.5"X1.5"	8		13	10	7	2.3							
FCP1100	1.1	1.5	6.4	30	17	330	2"X2"	8		16.5	14.5	12	9.3	6.2	3					
FCP1500	1.5	2	8.6	40	18	420	2"X2"	8		17	15.8	14	12	10	7.3	5				
FCP2200	2.2	3	13	50	20	510	2"X2"	8		19	17.5	16	15	13	11	9	7			

标准的电参数及零件配置: 单相220V/50Hz、不锈钢轴、马达内置热保护器。可根据客户的其它参数及材料的要求, 制作其它单、三相电压、60Hz、双电压、不锈钢轴等规格的产品。

Standard data and equipment: single phase 220V/50Hz, plastic impeller, carbon steel motor shaft, with terminal protector inside. Others model and material such as three phase, 110V, 60Hz, dual voltage, stainless steel shaft, etc, will be available upon request.